

# Billing Boats®

## U.S. Coast Guard 100\*

PHOTO MANUAL



### DK U.S. Coast Guard

Den første redningsbåd af denne type, blev søsat fra Coast Guard værftet i Curtis Bay, Maryland, U.S.A. i 1961. Det er bemærkelsesværdigt, at af de 110 Coast Guards, der blev bygget, blev kun en taget ud af drift. Fire af redningsbådene blev solgt til andre lande.

### GB U.S. Coast Guard

The first lifeboat of this type was launched in 1961 at the Coast Guard docks in Curtis Bay, Maryland in the USA. Of the 110 Coast Guards originally built, only one has since been taken out of service. Four of the vessels have been sold to other countries.

### D U.S. Coast Guard

Das erste Rettungsboot dieses Typs, lief 1961 von der Coast Guard Werft in Curtis Bay, Maryland, U.S.A. vom Stapel. Es ist bemerkenswert, dass aus 110 gebauten Coast Guards, nur ein einziger ausser Betrieb genommen wurde. Vier der Rettungsboote wurden an andere Länder verkauft.

### F U.S. Coast Guard

Le premier bateau de sauvetage de ce type fut lancé au Chantier Naval Coast Guard, à Curtis Bay, dans le Maryland, USA, en 1961. Ce qui est de remarquable est que sur les 110 bateaux construits, un seul fut retiré du service. Quatre de ces bateaux de sauvetage furent vendus à d'autres pays.

### NL U.S. Coast Guard

De eerste reddingsboot van dit type is in 1961 te water gelaten in de Coast Guard dokken in Curtis Bay, Maryland, U.S.A. Van de in totaal 110 stuks gebouwd, is er tot op heden nog maar een uit de dienst genomen. Vier stuks zijn geëxporteerd.

### E U.S. Coast Guard

La primera lancha de salvamento de este tipo fue botada en 1961 desde los astilleros Coast Guard en Curtis Bay, Maryland, EEUU. Es notable que de los 110 lanchas del tipo Coast Guard, que fueron construidas, solamente una fue sacada del servicio. Cuatro de las lanchas de salvamento fueron vendidas a otros países.

### I U.S. Coast Guard

Il primo battello da salvataggio di questo tipo è stato varato nel 1961 presso i cantieri "Coast Guard" a Curtis Bay, nello stato di Maryland, USA. Un particolare interessante è che tra le 110 imbarcazioni di questo tipo una sola è stata messa fuori servizio. Mentre quattro esemplari sono stati venduti in altri paesi

### P U.S. Coast Guard

O primeiro barco salva-vidas deste tipo foi lançado em 1961, nas docas da Guarda Costeira Americana na baía de Curtis, Maryland, nos EUA. Dos 110 barcos U.S. Coast Guard construídos, somente um foi colocado fora de serviço. Quatro desses barcos foram vendidos para outros países.

### PL U.S. Coast Guard

Pierwsza łódź ratunkowa tego typu została zwodowana w 1961 roku w dokach Straży Przybrzeżnej w Curtis Bay w stanie Maryland w USA. Spośród 110 pierwotnie zbudowanych jednostek straży przybrzeżnej tylko jedna została wycofana ze służby. Cztery statki zostały sprzedane do innych krajów.

### To see our color conversion chart please visit <https://www.billingboats.com/faq>

Til denne model er mahogni bejdse og farver med følgende numre nødvendige:

For this model is mahogany stain and colours with the following numbers should be used:

Für dieses Modell sind Mahagoni Beize und Farben mit den folgenden Nummern notwendig:

Pour ce modèle, le mordant et les couleurs avec les numéros suivants doivent être employés:

Voor dit model zijn kleuren met de volgende nummers nodig:
















Para est modelo se necesitan mordiente et colores con los siguientes números:

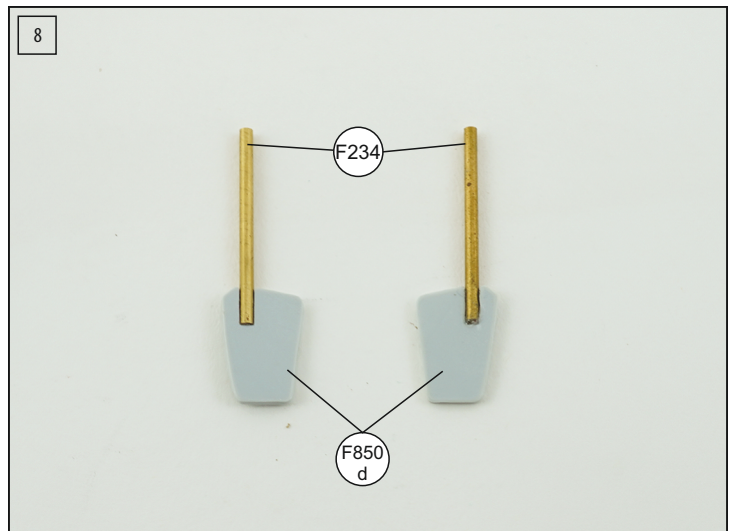
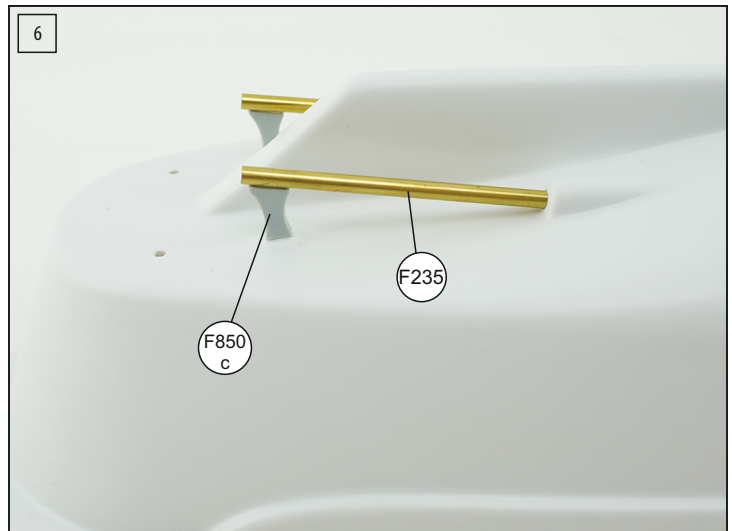
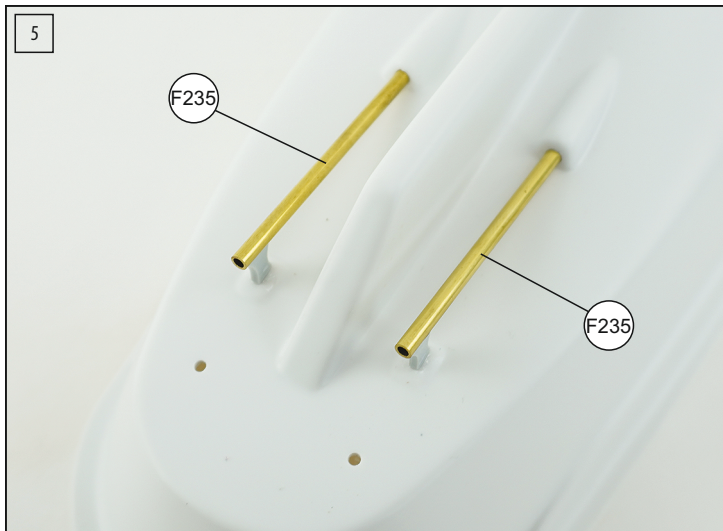
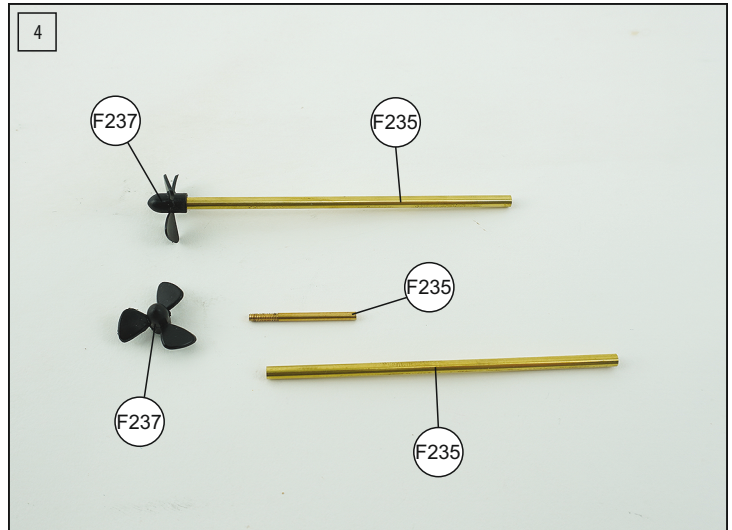
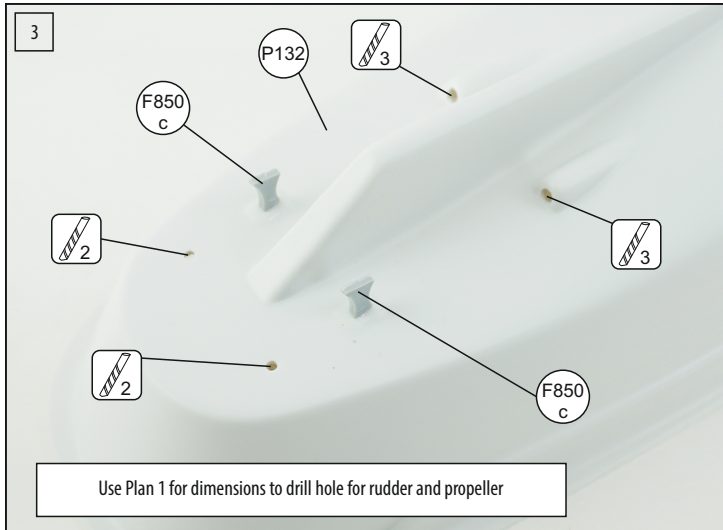
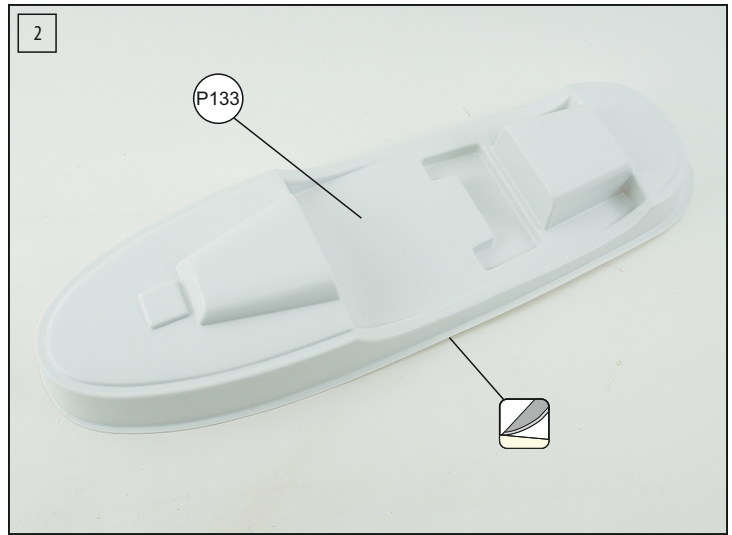
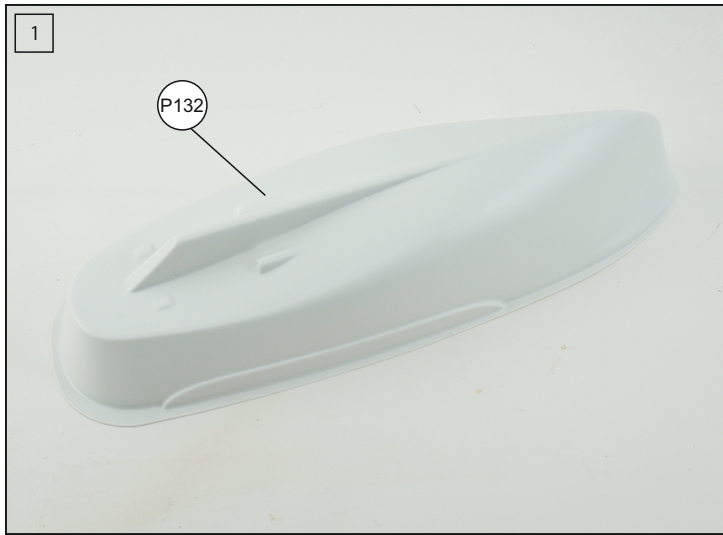
Per questo modello occorrono inchiostro tinteggiatore "mogano" e colori con questi numeri:

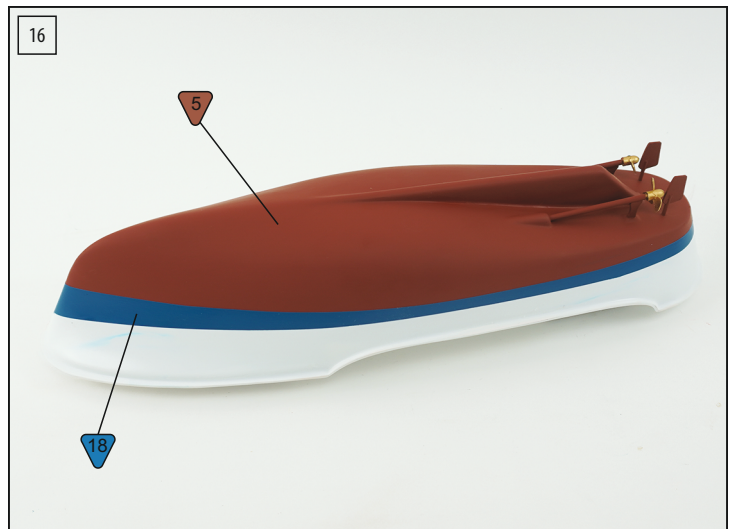
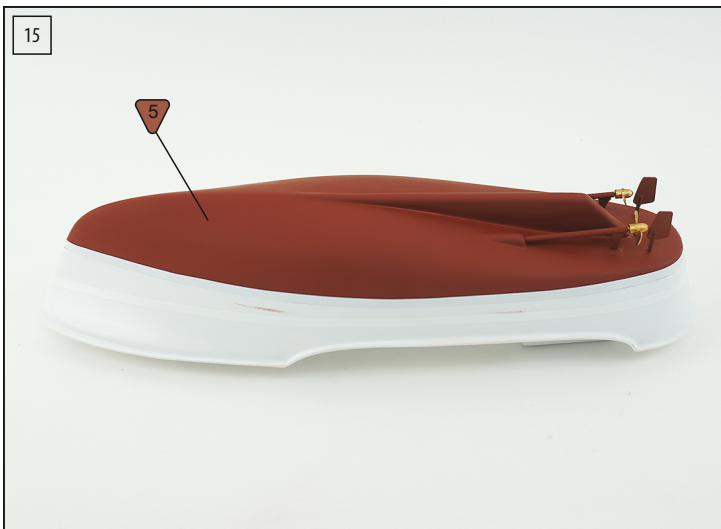
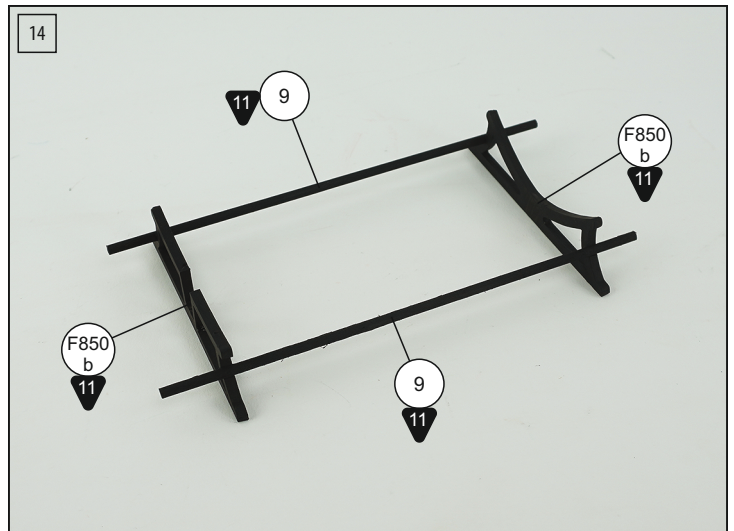
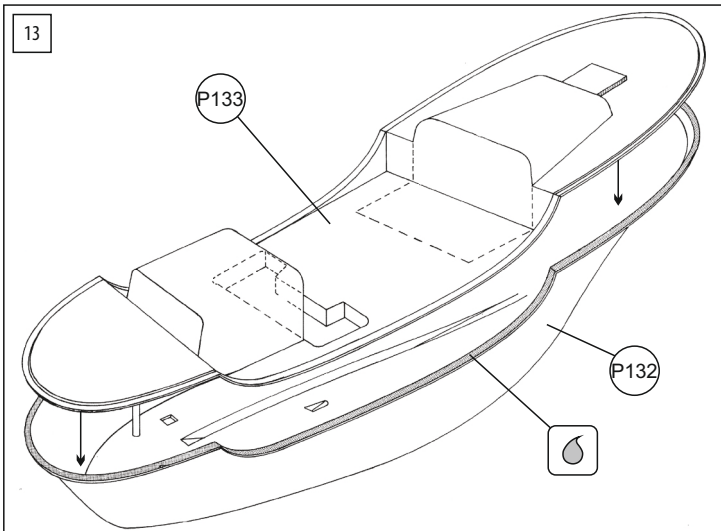
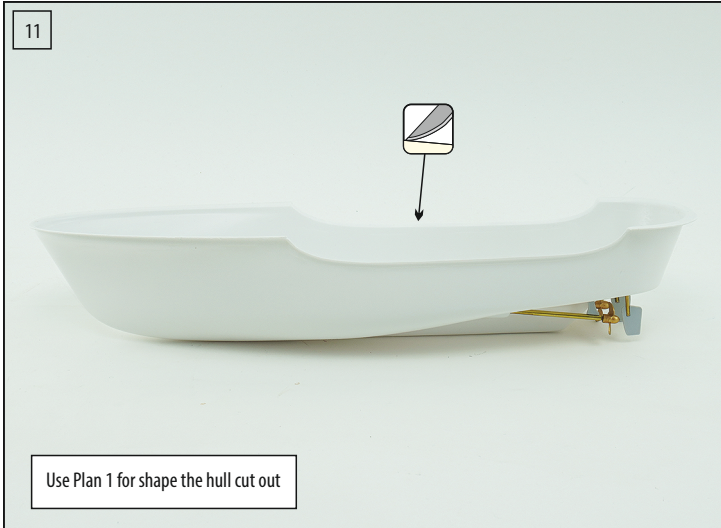
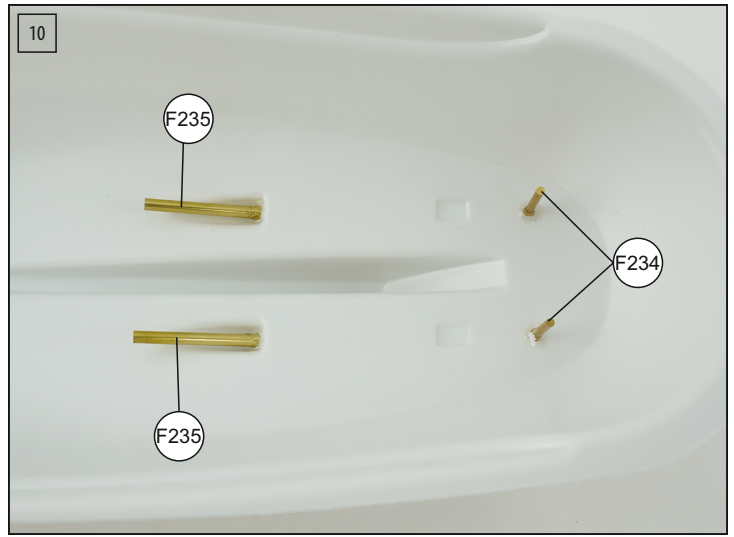
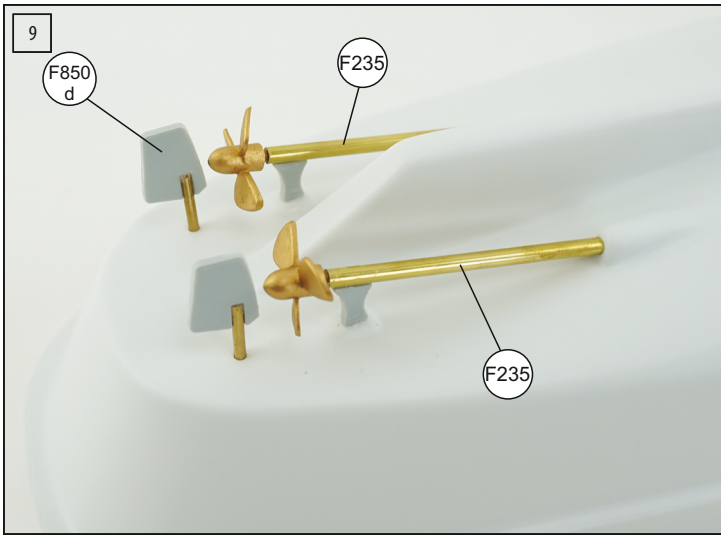
Pinte o modelo com tintura cor Mogno e as cores sugeridas da Billing Boats:

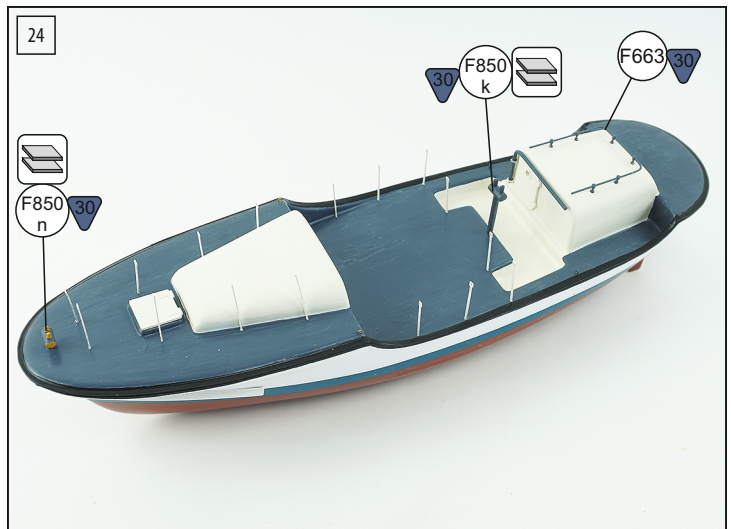
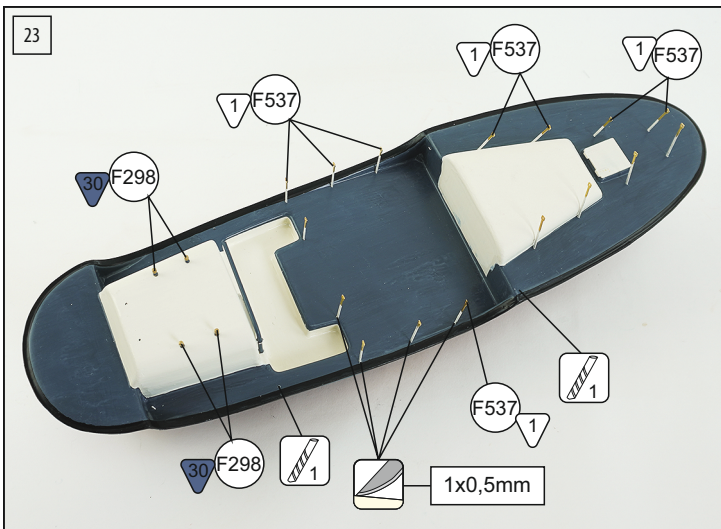
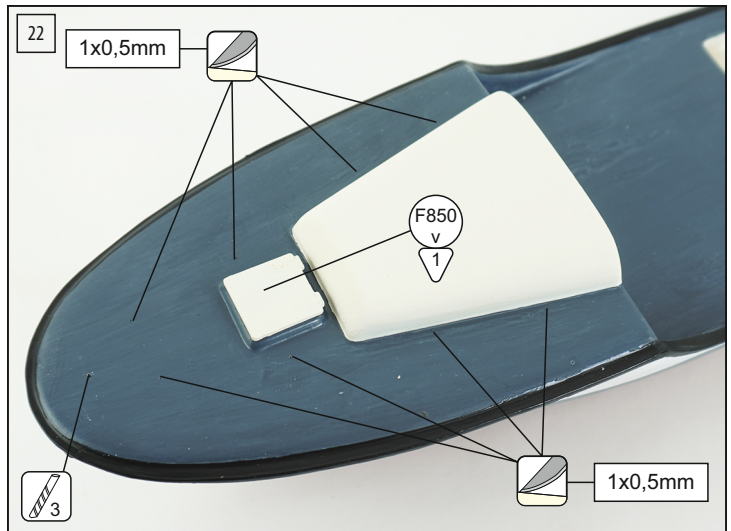
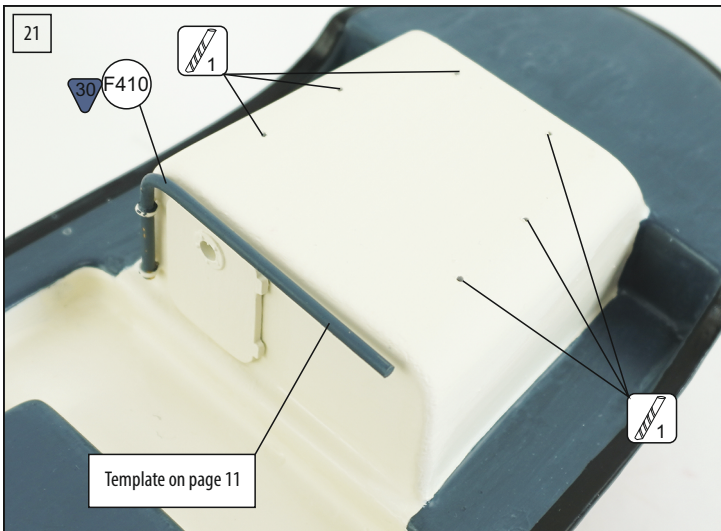
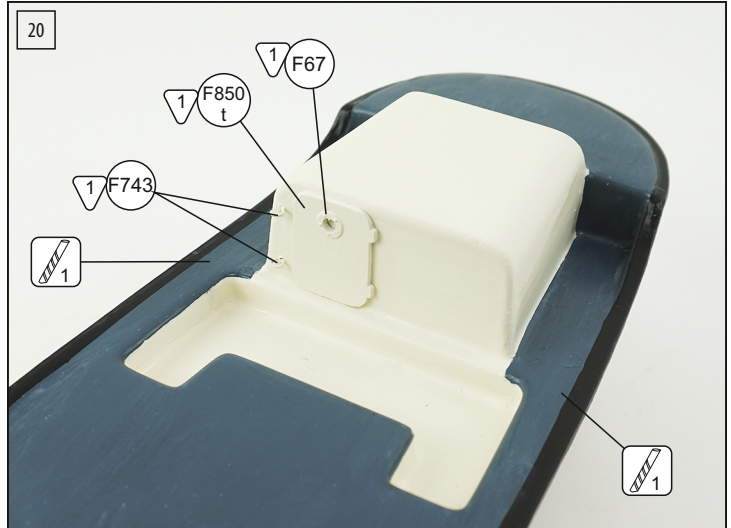
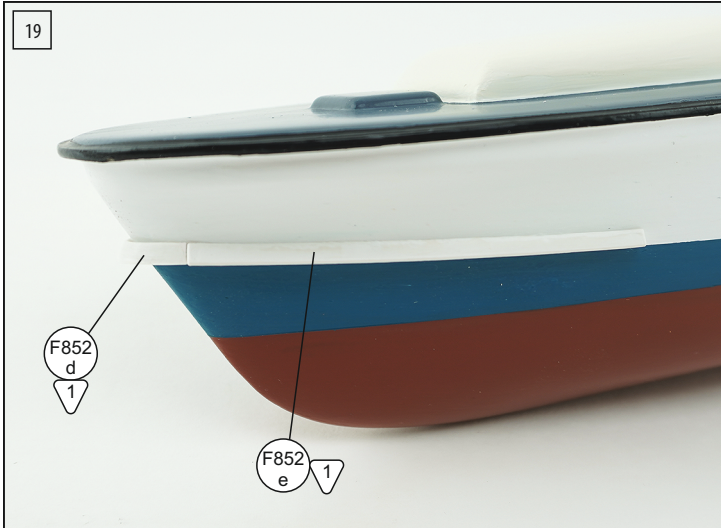
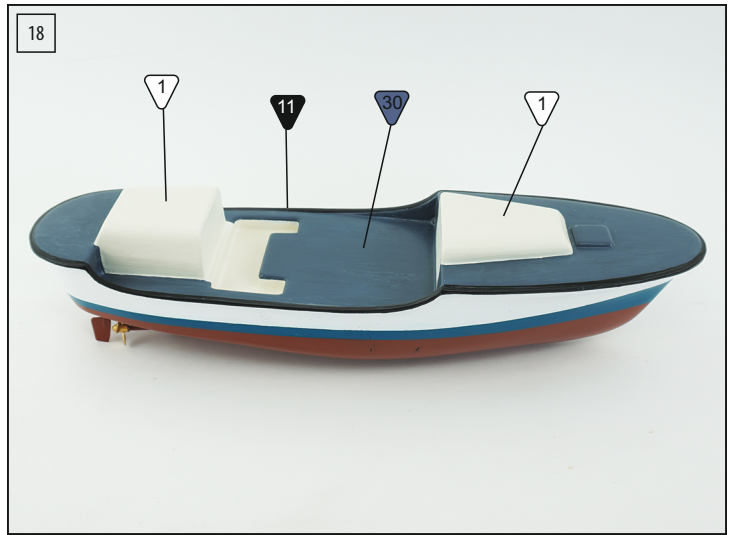
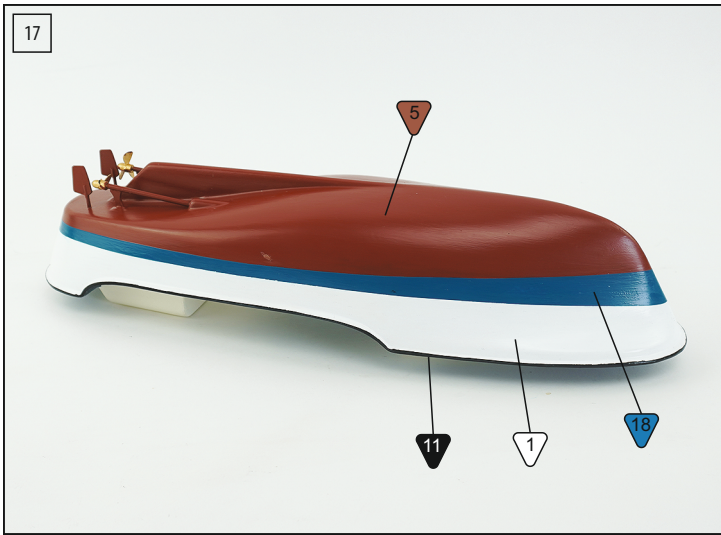
W przypadku tego modelu należy użyć bejcy mahoniowej oraz farby o numerach:

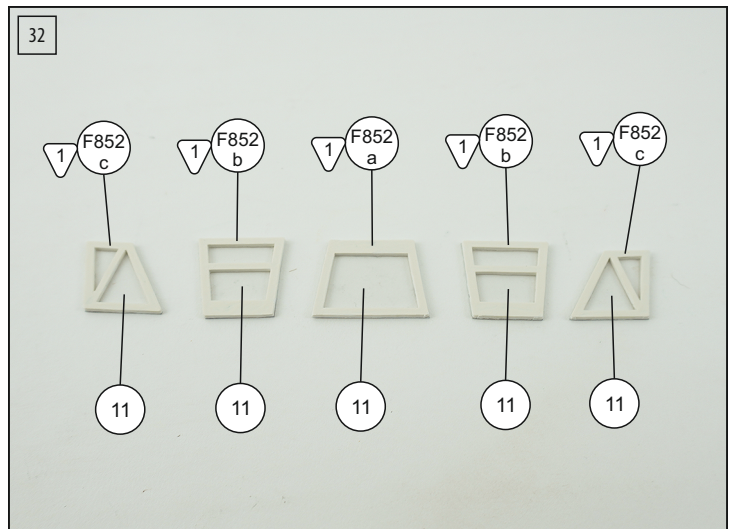
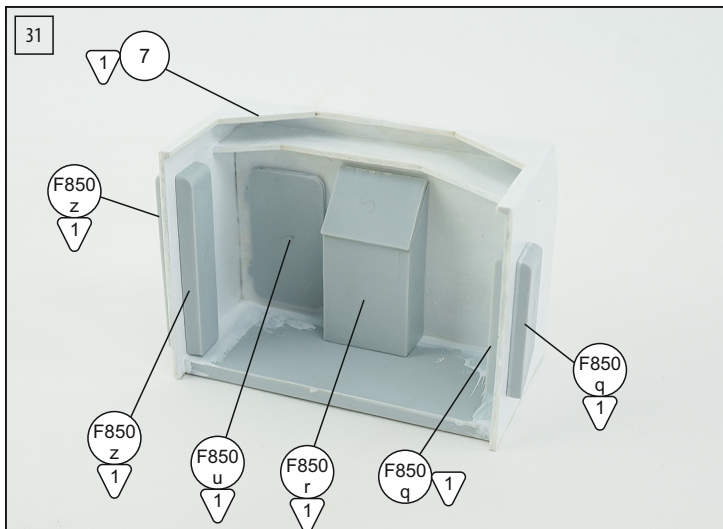
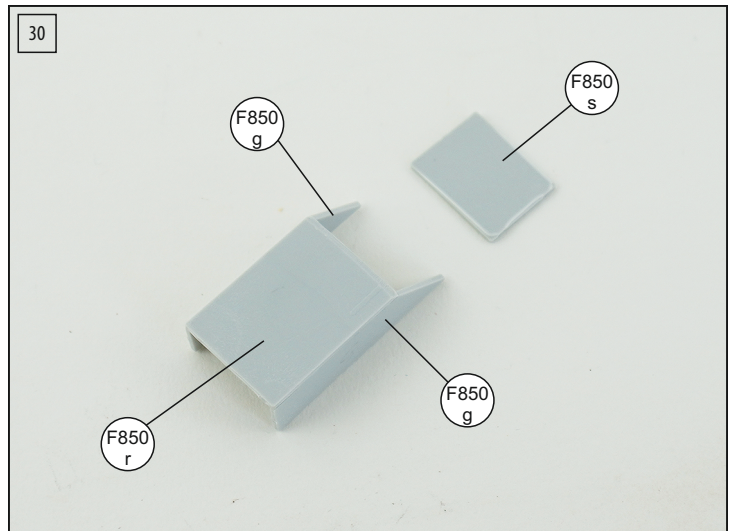
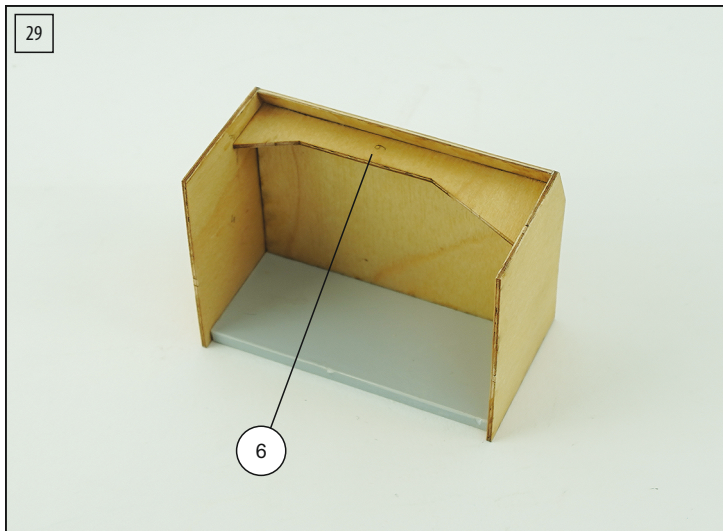
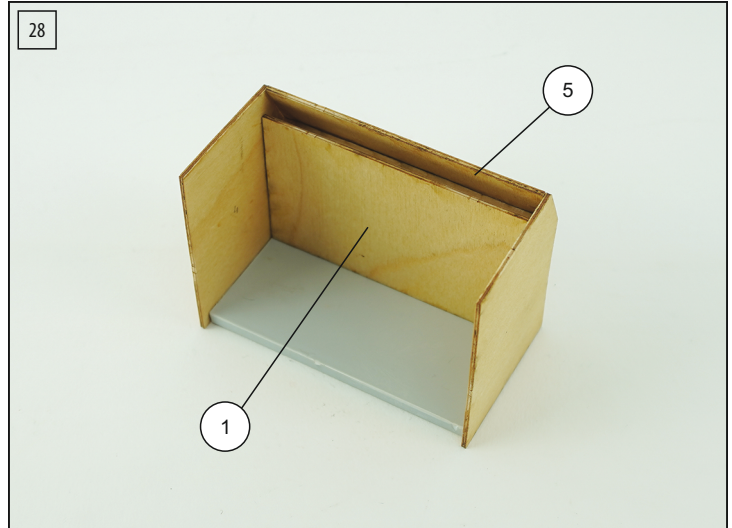
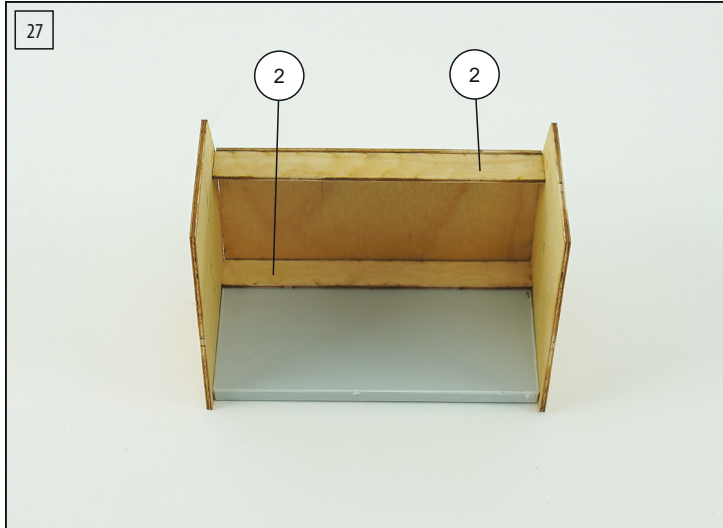
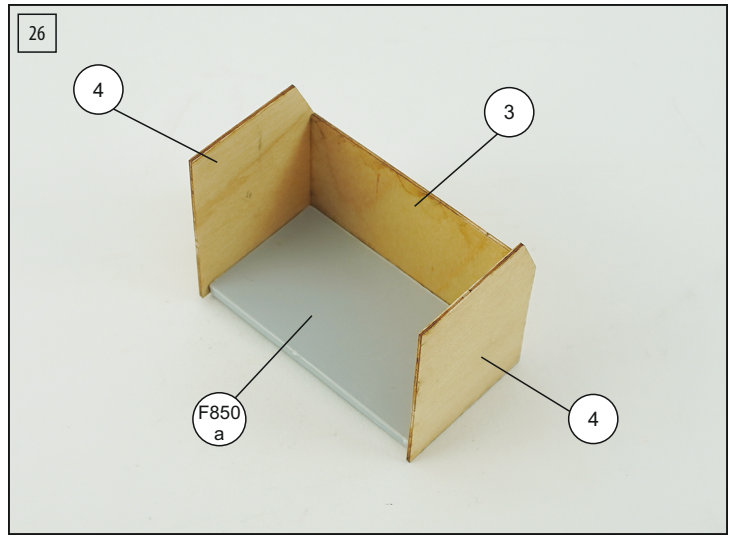
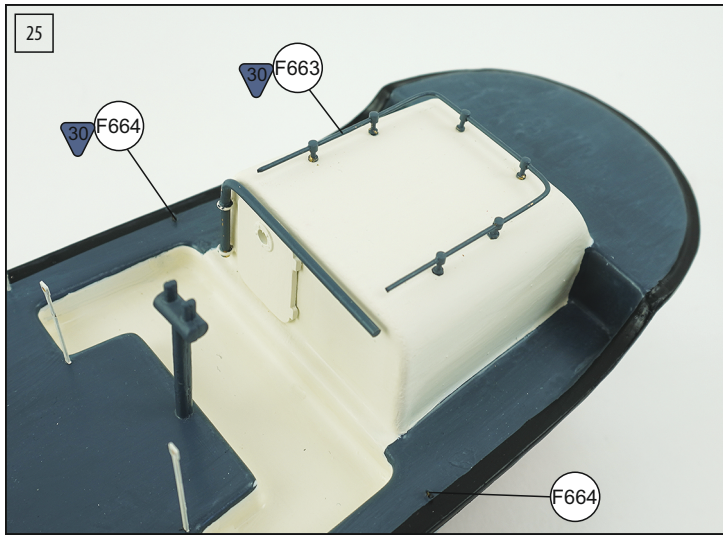
Billing 1	= White
Billing 5	= Tan
Billing 9	= Bright Red
Billing 11	= Black
Billing 13	= Trainer Yellow
Billing 15	= Silver
Billing 16	= Gold
Billing 18	= Mediterranean Blue
Billing 30	= Dark Ad Grey

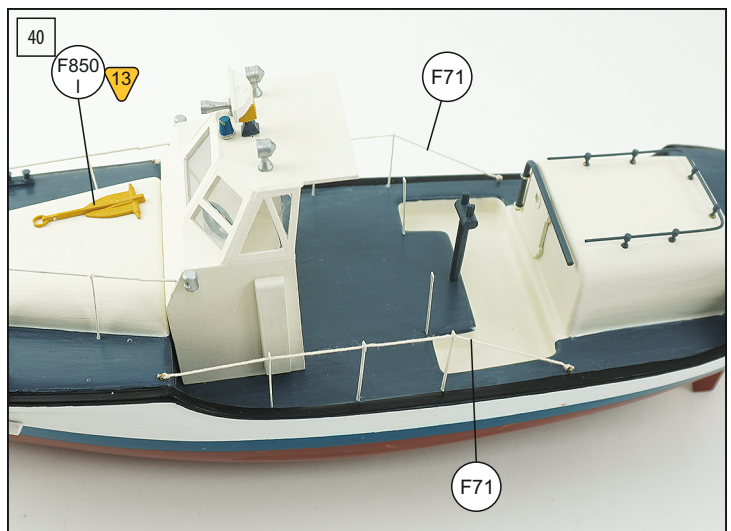
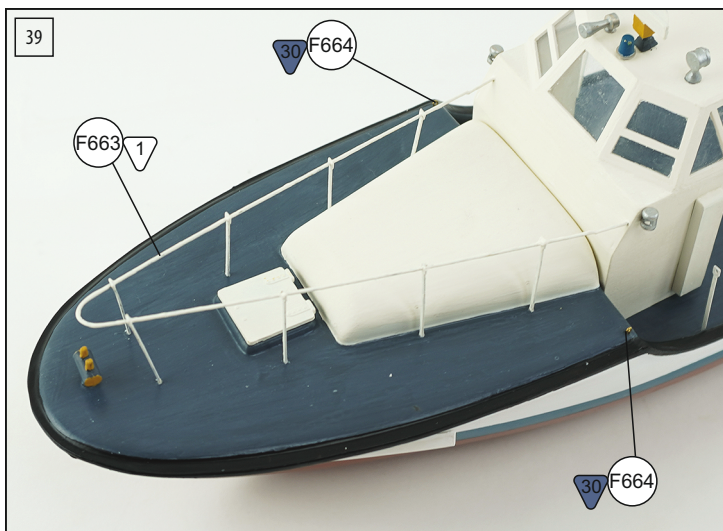
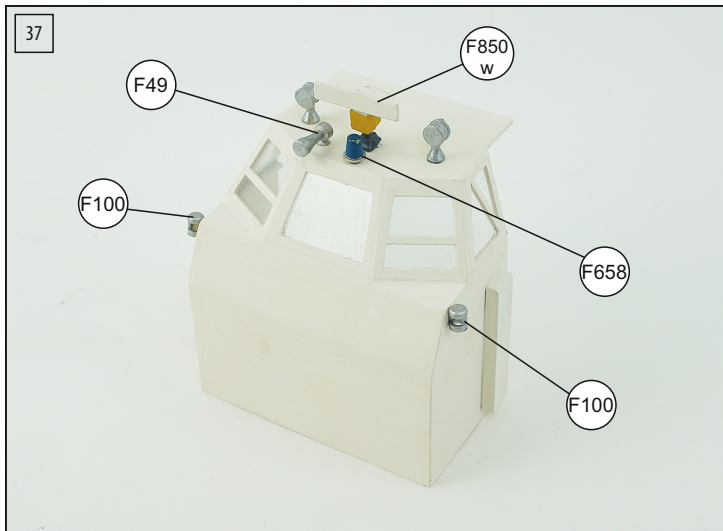
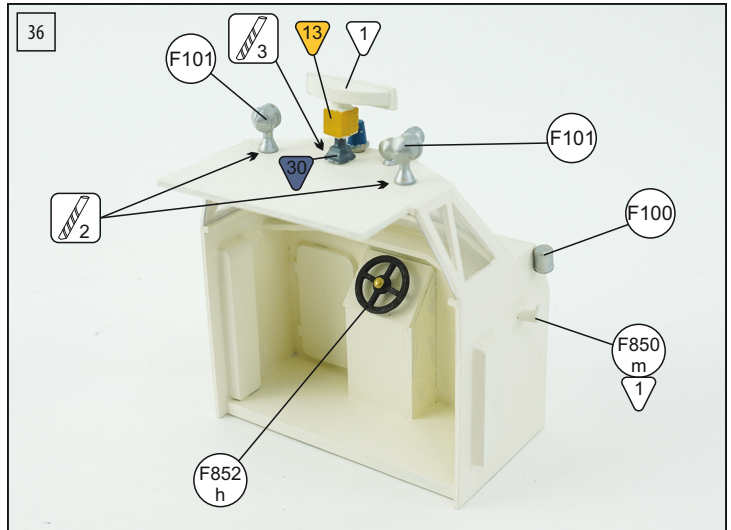
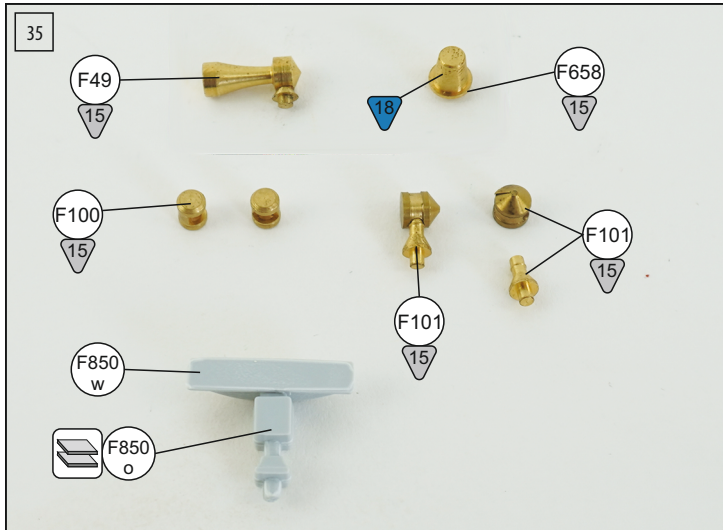
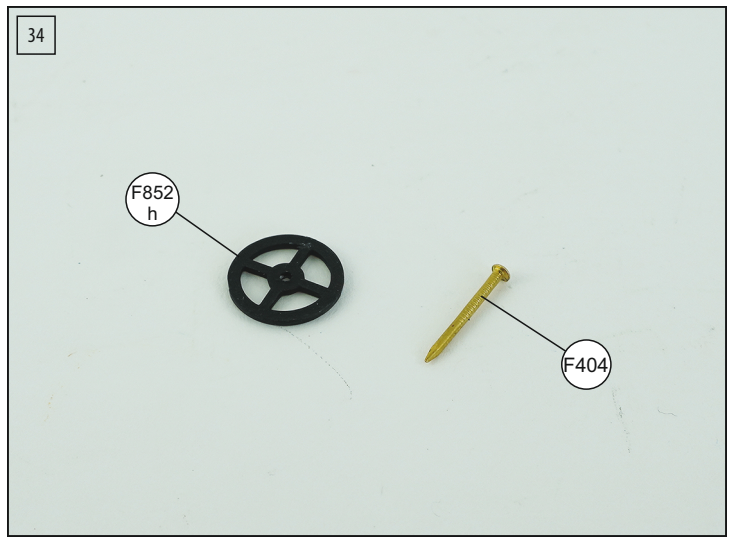
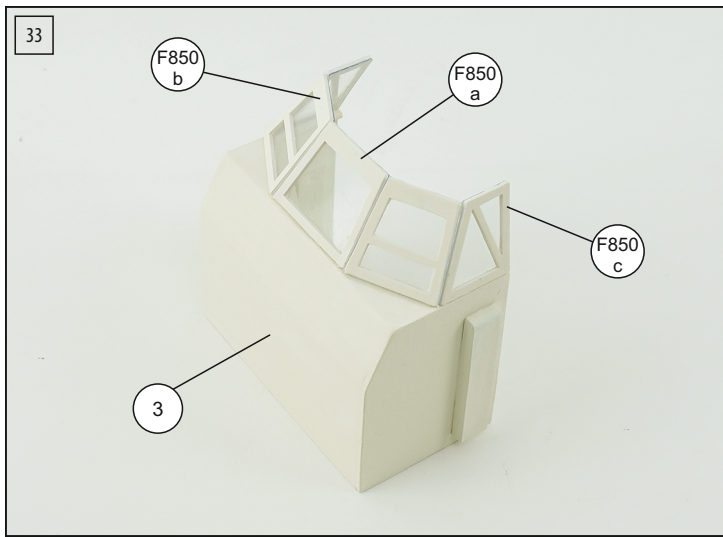
	Part number		Cut out		Paint with primer paint
	Paint number (* alternative colour)		Use putty (fill and sand)		Use cyanoacrylate glue
	Wood stain		Fit to other parts		Give shape (before sticking)
	Rope number		Part made with layers		Give shape (before sticking, if necessary use water)
	Give shape (for example use sand paper)		Drill a hole (x mm)		Roll up

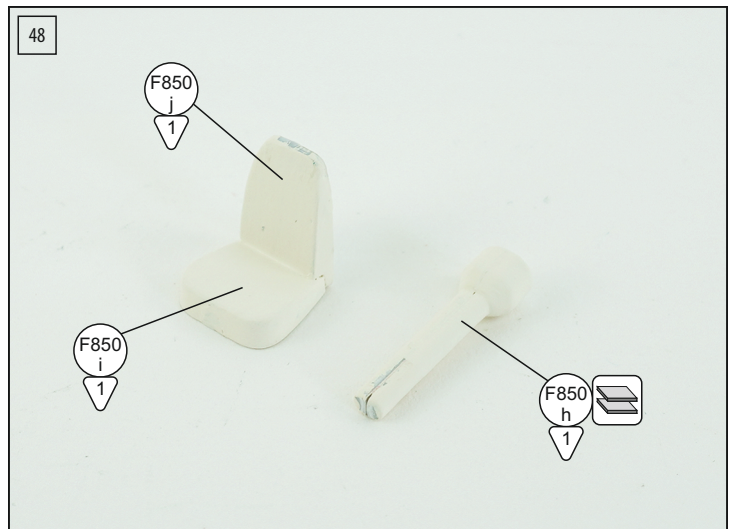
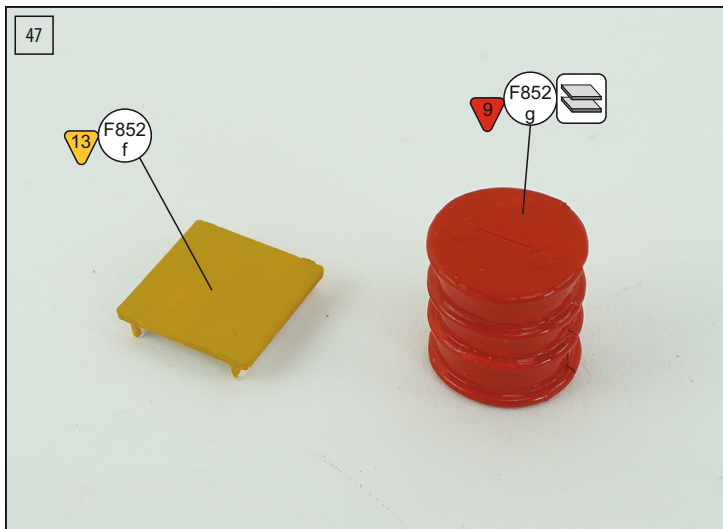
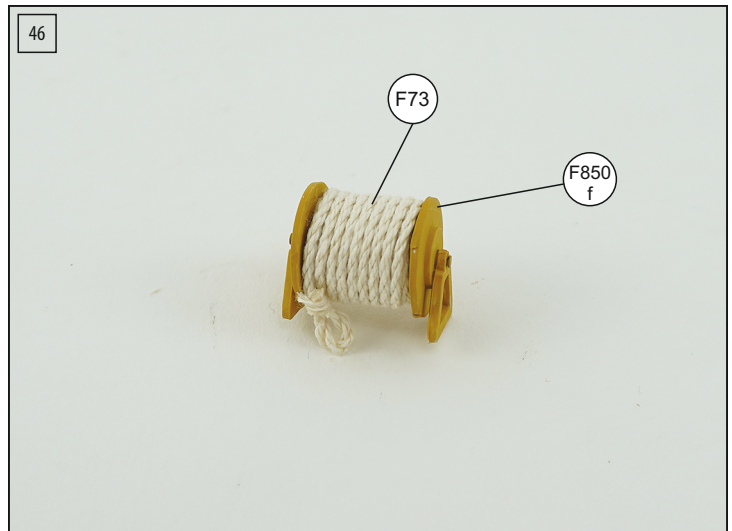
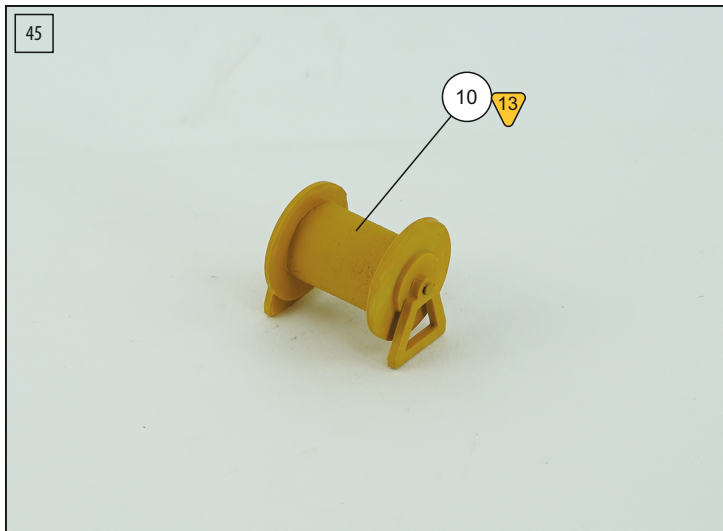
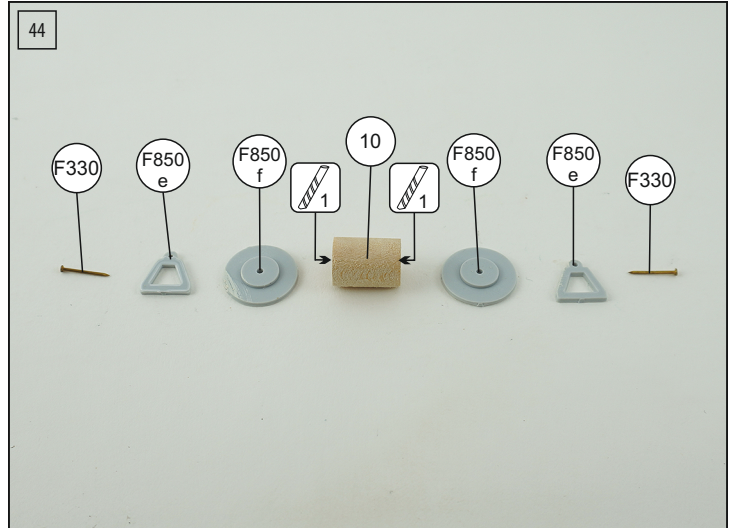
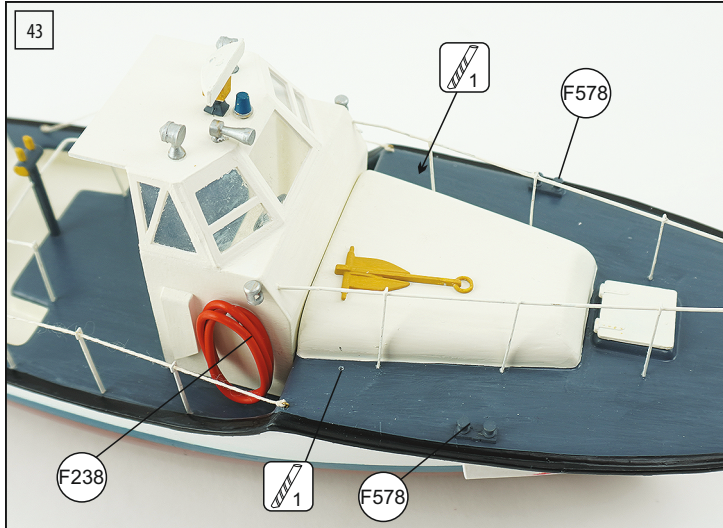
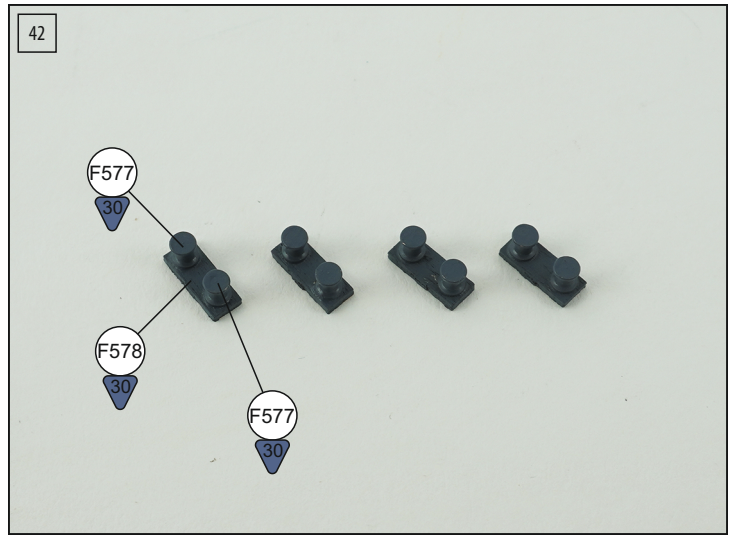
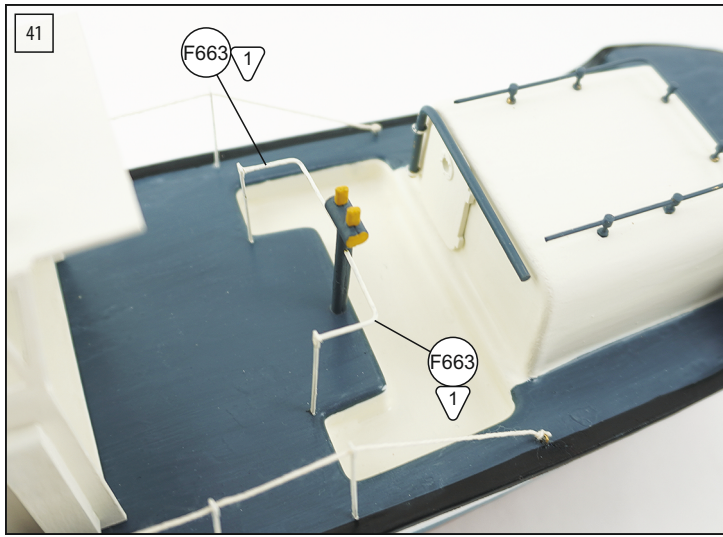


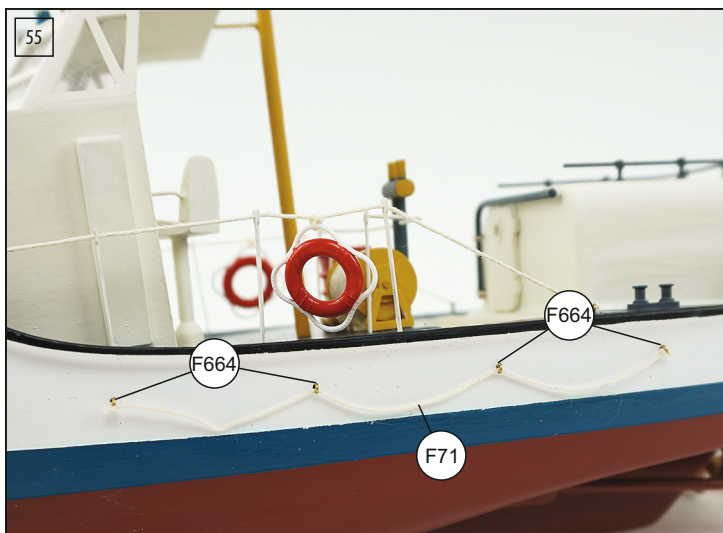
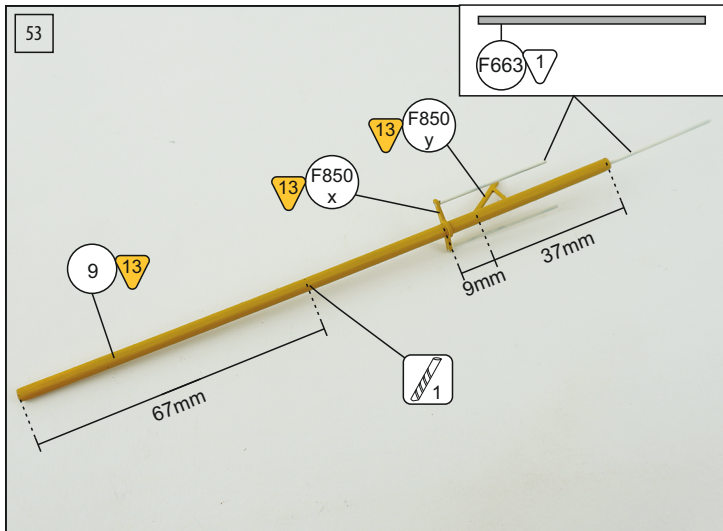
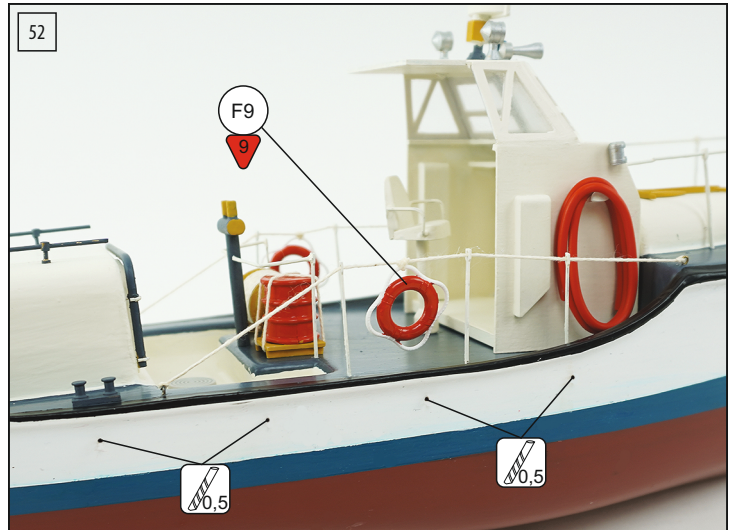
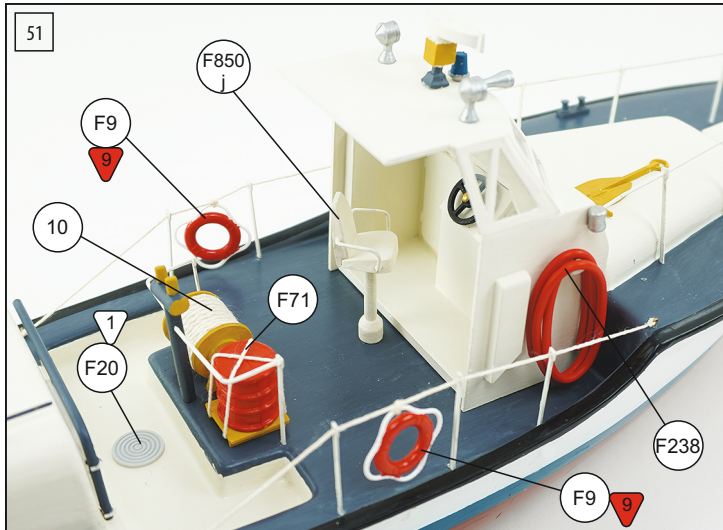
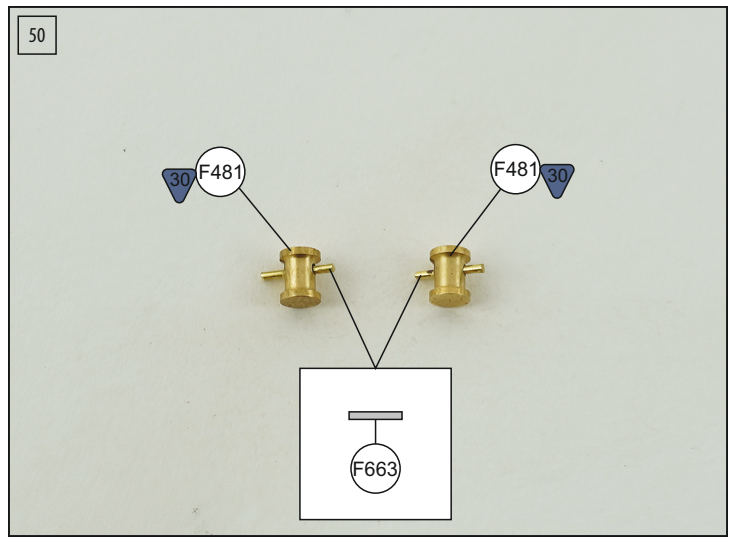
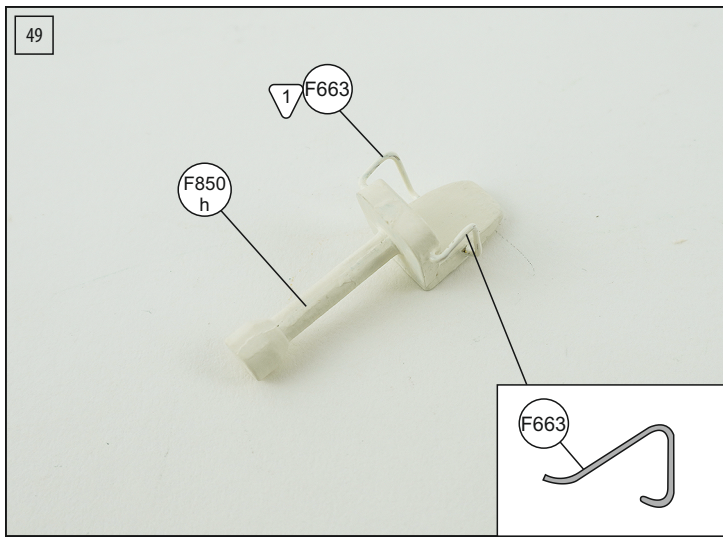






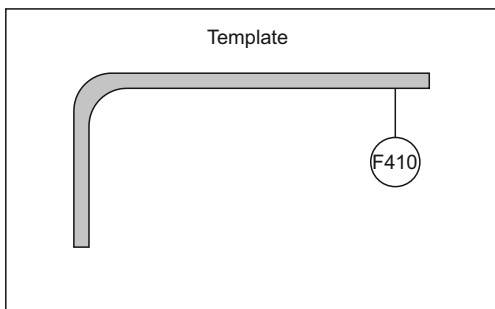
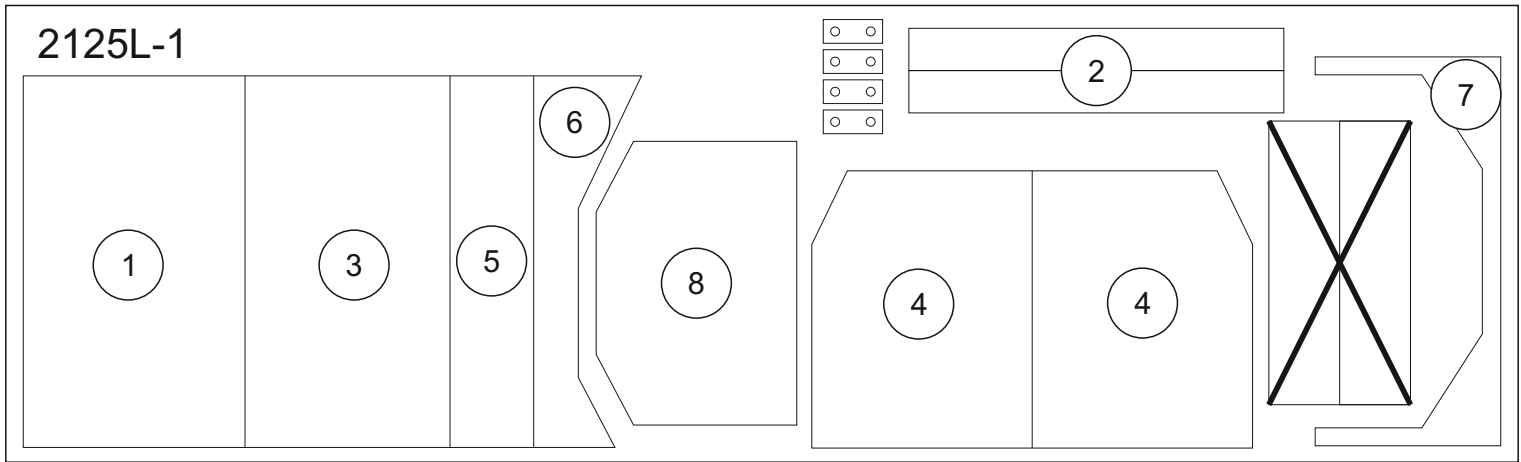
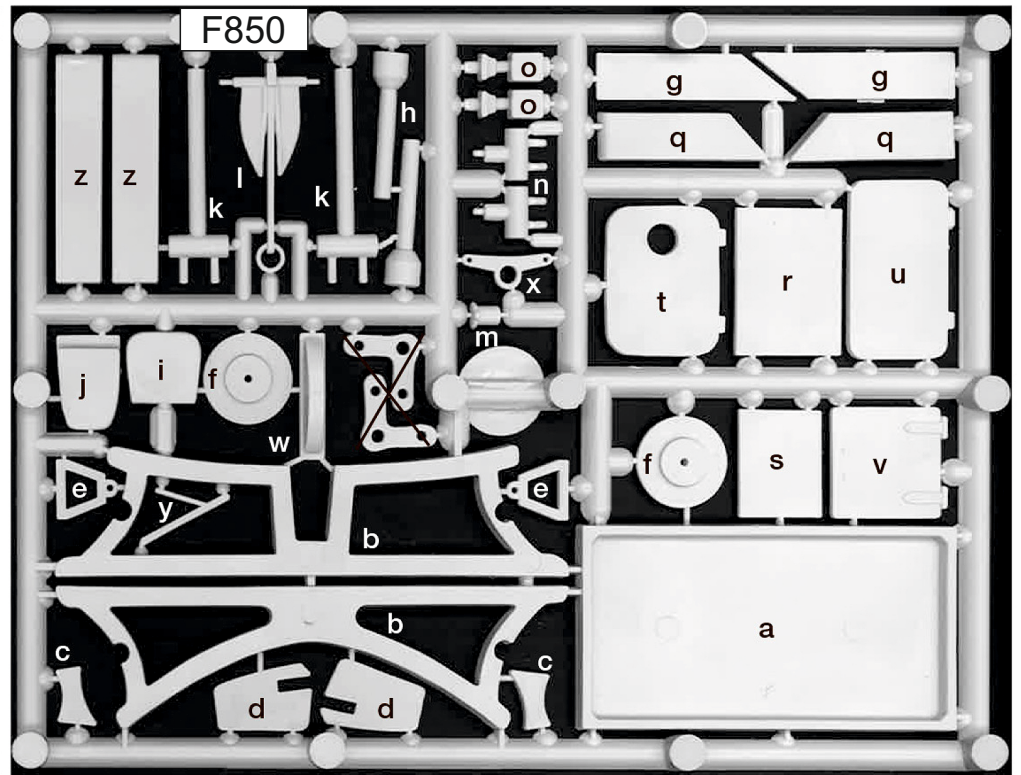
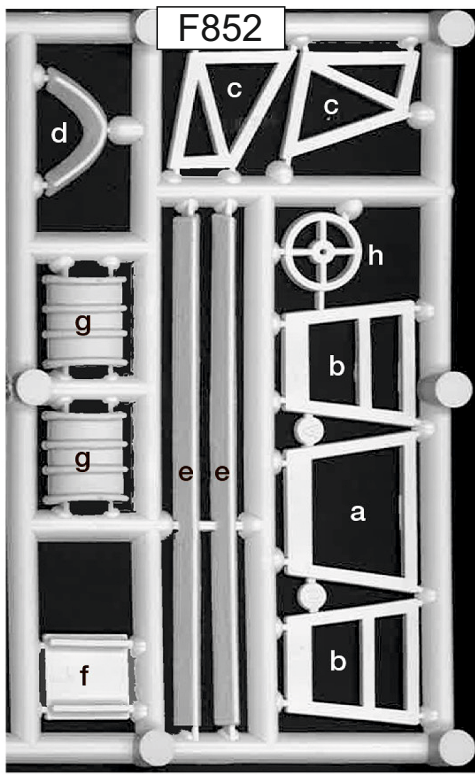


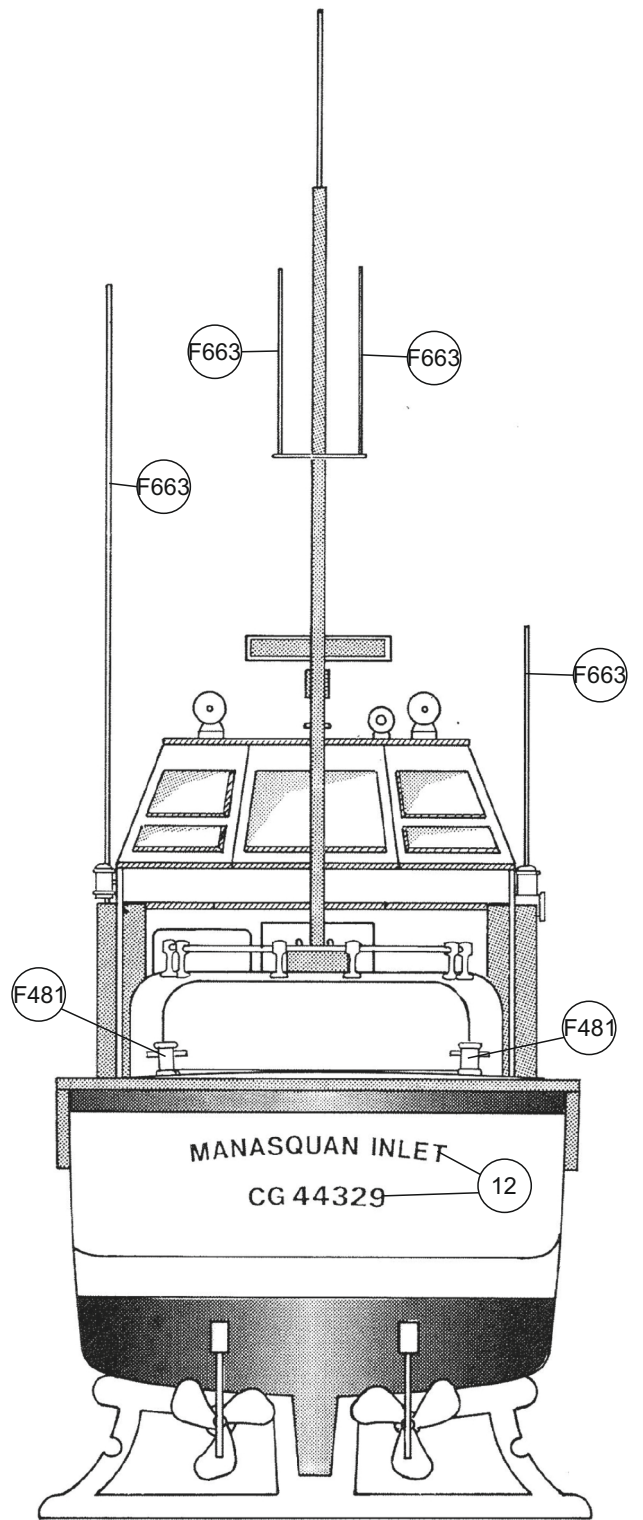
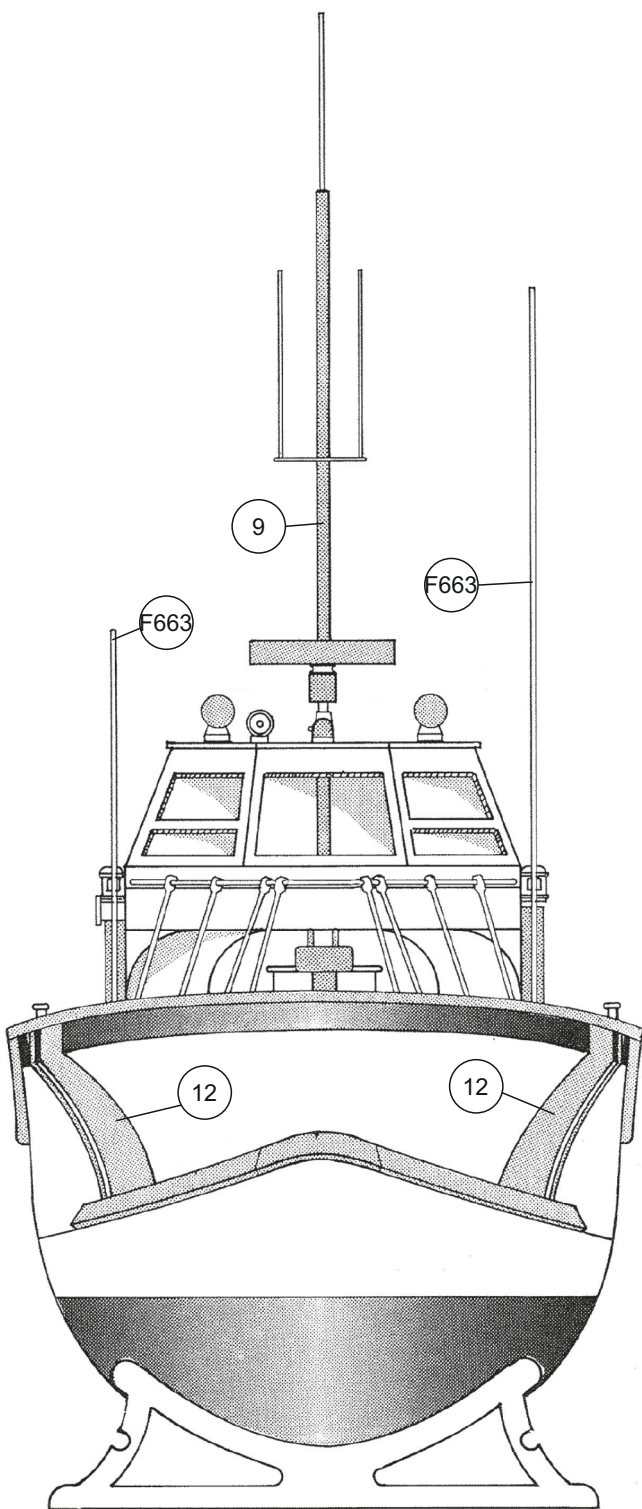












**Table of contents for U.S. Coast Guard Art. No. 100**

Pcs.	No.	Dimension	Material	DK	GB	D	F	NL
1	P132	ABS		Skrog	Hull	Rumpf	Coque	Romp
1	P133	ABS		Dæk	Deck	Deck	Pont	Dek
1	1	1mm x-veneér	2125L	Kahyt	Cabin	Kajüte	Cabine	Kajuit
2	2	1mm x-veneér	2125L	Kahyt	Cabin	Kajüte	Cabine	Kajuit
1	3	1mm x-veneér	2125L	Kahyt	Cabin	Kajüte	Cabine	Kajuit
2	4	1mm x-veneér	2125L	Kahyt	Cabin	Kajüte	Cabine	Kajuit
1	5	1mm x-veneér	2125L	Kahyt	Cabin	Kajüte	Cabine	Kajuit
1	6	1mm x-veneér	2125L	Kahyt	Cabin	Kajüte	Cabine	Kajuit
1	7	1mm x-veneér	2125L	Kahyt	Cabin	Kajüte	Cabine	Kajuit
1	8	1mm x-veneér	2125L	Kahyt	Cabin	Kajüte	Cabine	Kajuit
3	9	ø3x155mm		Bedding	Slip	Ständer	Cale	Standaard
1	10	ø10x13mm		Tovtromle	Wire winch	Seilrolle	Rouleau de cordage	Touw-trommel
1	11	2,5x110mm		Acetat	Acetate	Azetat	Rhodoid	Acetaat
1	12	TR128		Transfer	Transfer	Abziehbild	Decalcomanies	Transfer
1				Byggevejledning	Building instruction	Bauanleitung	Instruction de montage	Bouwbeschrijving
1				Hovedtegninger	Plans	Zeichnungen	Plans	Tekening
2	F9	ø15mm	Plastic	Redningskrans	Lifering	Retningsring	Ceinture sauvetage	Reddingsboei
1	F20	ø12mm	Plastic	Isdæksel	Icecover	Eisdeckel	Couvercle de bac à glace	Ijsdæksel
1	F39	ø1x250mm	Brass	Messingtråd	Brass wire	Messingdråht	Fils de laiton	Messingdraad
1	F49	11mm	Brass	Sirene	Siren	Sirene	Sirène	Sirene
1	F67	ø5mm	Plastic	Kooje	Portlight	Bullauge	Hublot	Patrijspoort
1	F71	1m	Thread	Rigningstråd	Rigging thread	Takelgarn	Fil de grément	Takelgaren
1	F73	0,5m	Thread	Rigningstråd	Rigging thread	Takelgarn	Fil de grément	Takelgaren
2	F100	ø4x5mm	Brass	Lys	Light	Licht	Feux	Licht
2	F101	ø5mm	Brass	Spotlight	Searchlight	Scheinwerf	Projecteur	Schijnwerper
2	F234	30mm	Brass	Rudder	Ror	Ruder	Gouvernail	Roer
2	F235	ø3mm	Brass	Propelaksel	Propeller shaft	Stevenrohr	Arbre porte hélice	Schroefas
2	F237	ø20mm	Plastic	Skibsskrue	Propeller	Schiffsschraube	Hélice	Propeller
1	F238		Cable	Elkabel	Cable	Kabel	Cable	Kabel
6	F298	ø2x7,4mm	Brass	Gelænderstøtte	Rail stanchion	Reiingsstütze	Chandelier	Railingpaal
2	F330	ø1x10mm	Brass	Søm	Nail	Nägel	Clou	Spijkertje
1	F404	ø1x15mm	Brass	Søm	Nail	Nägel	Clou	Spijkertje
1	F410	ø2x250mm	Brass	Messingtråd	Brass wire	Messingdråht	Fils de laiton	Messingdraad
2	F481	ø4x5mm	Brass	Pullert	Bollard	Poller	Bitte d'amarrage	Bolder
16	F537	25mm	Brass	Plade ved rosjern	Chain plate	Platte f. Nagelbank	Plan. p. fixation	Versterking putting
8	F577	ø3x4mm	Brass	Pullert	Bollard	Poller	Bitte d'amarrage	Bolder
1	F658	ø5x6mm	Brass	Lanterne	Lantern	Lanterne	Lanterne	Boordlichten
2	F663	Ø0,7x250mm	Brass	Messingtråd	Brass wire	Messingdråht	Fils de laiton	Messingdraad
14	F664	11mm	Brass	Øjebolt	Eye bolt	Augbolzen	Pitons	Oogbout
2	F743	9mm	Brass	Øjebolt	Eye bolt	Augbolzen	Pitons	Oogbout
1	F850		Plastic	Plastikstøb	Plastic steep	Plastikspritziing	Plastic moulage	Plastiek giet
1	F852		Plastic	Plastikstøb	Plastic steep	Plastikspritziing	Plastic moulage	Plastiek giet

**Table of contents for U.S. Coast Guard Art. No. 100**

Pcs.	No.	Dimension	Material	E	I	P	PL
1	P132	ABS		Casco	Scafo	Casco	Kadhub
1	P133	ABS		Cubierta	Ponte	Convés	Pokład
1	1	1mm x-veneér	2125L	Camarote	Cabina	Cabine	Kabina
2	2	1mm x-veneér	2125L	Camarote	Cabina	Cabine	Kabina
1	3	1mm x-veneér	2125L	Camarote	Cabina	Cabine	Kabina
2	4	1mm x-veneér	2125L	Camarote	Cabina	Cabine	Kabina
1	5	1mm x-veneér	2125L	Camarote	Cabina	Cabine	Kabina
1	6	1mm x-veneér	2125L	Camarote	Cabina	Cabine	Kabina
1	7	1mm x-veneér	2125L	Camarote	Cabina	Cabine	Kabina
1	8	1mm x-veneér	2125L	Camarote	Cabina	Cabine	Kabina
3	9	ø3x155mm		Grada	Listello	Tiras	Podstawa
1	10	ø10x13mm		Tambor de cordaje	Tamburo della gomema	Tambor do guincho	Wciągarka
1	11	2,5x110mm		Acetate	Acetato	Acetate	Folia
1	12	TR128		Calcas	Decalcomania	Decalque	Kalkomania
1				Instrucciones de montaje	Istruzioni di montaggio	Instruções de montagem	Instrukcja budowy
1				Planes	Piani	Planos	Rysunki
2	F9	ø15mm	Plastic	Cinturones salvavidas	Scialuppa da salvataggio	Bóia salva-vidas	Koło ratunkowe
1	F20	ø12mm	Plastic	Tapa de hielo	Coprighiaccio	Tampa de gelo	Pokrywa
1	F39	ø1x250mm	Brass	Hilo de latón	Filo in ottone	Fio de latão	Drut
1	F49	11mm	Brass	Sirena	Sirena	Sirene	Syrena
1	F67	ø5mm	Plastic	Portilla	Obiò	Luz de bombordo	Lampa
1	F71	1m	Thread	Hilo de aparejo	Filo per manovre	Linha de cordame	Lina
1	F73	0,5m	Thread	Hilo de aparejo	Filo per manovre	Linha de cordame	Lina
2	F100	ø4x5mm	Brass	Luz	Leggero	Luzes	Lampa
2	F101	ø5mm	Brass	Reflector	Proiettore	Holofote	Lampa
2	F234	30mm	Brass	Timón	Timone	Leme	Ster
2	F235	ø3mm	Brass	Je de hélice	Albero porta-elica	Eixo da hélice	Wał
2	F237	ø20mm	Plastic	Hélice	Elica	Hélice	Śruba
1	F238		Cable	Cables	Cavo	Cabo	Kabel
6	F298	ø2x7,4mm	Brass	Soporte de pasamanos	Supporti per corrimano	Poste de trilho	Poręcz
2	F330	ø1x10mm	Brass	Clavo	Chiodo	Prego	Gwóźdź
1	F404	ø1x15mm	Brass	Clavo	Chiodo		Gwóźdź
1	F410	ø2x250mm	Brass	Hilo de latón	Filo in ottone	Fio de latão	Drut
2	F481	ø4x5mm	Brass	Bolardo	Bitta	Poste de amarração	Pacholek
16	F537	25mm	Brass	Cadenote	Lastra cavigliera	Fixador do ovém	Płyta
8	F577	ø3x4mm	Brass	Bolardo	Bitta	Poste de amarração	Pacholek
1	F658	ø5x6mm	Brass	Linterna	Lanterna	Lanternas	Latarnia
2	F663	Ø0,7x250mm	Brass	Hilo de latón	Filo in ottone	Fio de latão	Drut
14	F664	11mm	Brass	Perno de cáncamo	Bullone ad occhio	Ferrolho	Oko
2	F743	9mm	Brass	Perno de cáncamo	Bullone ad occhio	Ferrolho	Oko
1	F850		Plastic	Piezas de plastico	Pezzo stampato	Amarração Plastica	Części plastikowe
1	F852		Plastic	Piezas de plastico	Pezzo stampato	Amarração Plastica	Części plastikowe



## **Billing Boats**

[www.billingboats.com](http://www.billingboats.com)  
[service@billingboats.dk](mailto:service@billingboats.dk)